

CAD FILE:

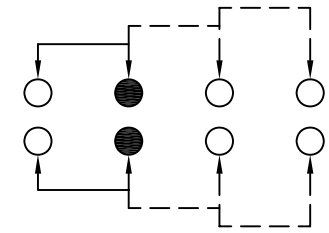

SCHEMATIC (NON-SHORTING)

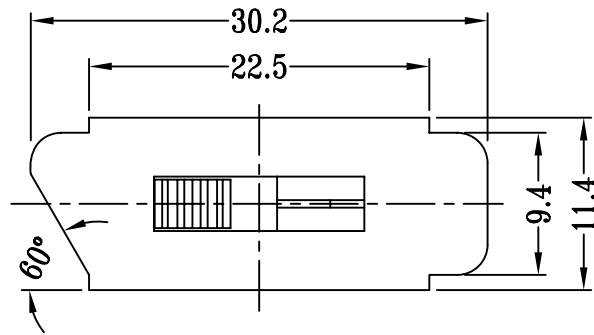
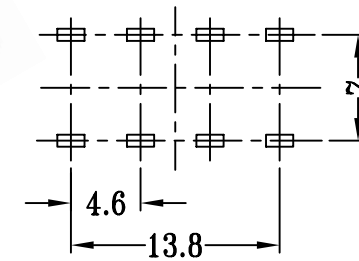
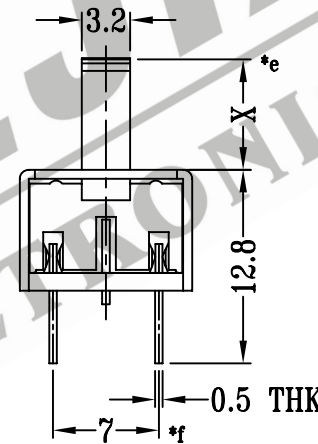
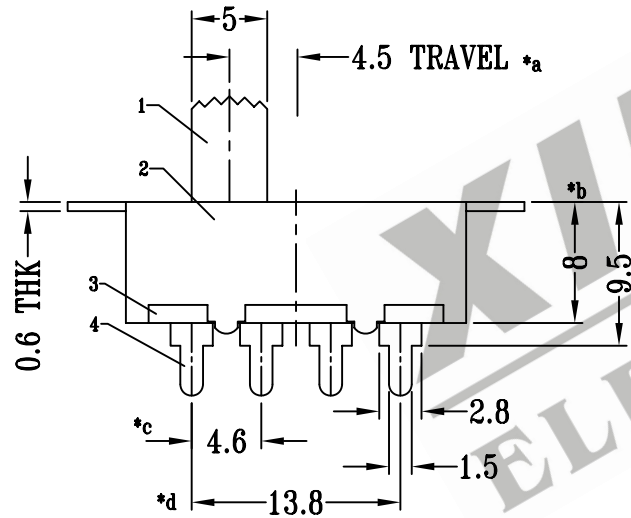

P.C.B LAYOUT

注:带"*"表示关键尺寸(6个)

8	SPRING PLATE	STEEL STRIP	1	Ni PLATED	TOLERANCE UNLESS SPECIFIED	SHENZHEN XIEJIA ELECTRONICS CO.,LTD.				
7	STRING	STEEL WIRE	1	TEMPER						
6	CONATCT CLIP	PBS	2	Ag CLAD	WITHIN: 1.5±0.1mm OVER : 1.5±0.2mm	ISSUE	DATE	DESCRIPTIONS		APPD
5	STEEL BALL	STEEL	1	NATURAL		TITLE: VERTICAL SLIDE SWITCH	UNIT : MM	DRWG NO.: XJ-DR-SS23102-00		
4	TERMINAL	BRASS STRIP	8	Ag PLATED OVER Ni PLATED	MODEL: SS-23102	SCALE: 2 : 1	DWN	ZHOUYU	2001-7-19	
3	BASE	PHENOLIC RESIN	1	BLACK			CHK'D	FANGYING	2001-7-19	
2	FRAME	STEEL STRIP	1	Ni PLATED	ALL MATERIALS MUST BE COMPLIANT TO ROHS	APPD	KANGXINAN	2001-7-19		
1	KNOB	PC	1	BLACK						
NO.	PART NAME	MATERIAL	QTY	FINISHING						